



OEM DPSS Laser Source

AQS 6 OEM



Features

- Compact Air Cooled Source
- Low Power Consumption
- Rep. Rate till 200KHz
- Small Footprint
- Configurable Beam Expander
- Red Aiming Beam
- Remote Software Interface & Diagnostic

Applications

- Industrial Marking
- Material Processing
- ID
- Fine Ablation



OEM DPSS Laser Source

AQS6 OEM

AQS6

Laser Type Medium		Nd:YVO ₄
Wavelength	[nm]	1064
Average Power	[W]	6 CW
Rep. Rate	[kHz]	10 - 100 in Q-Switch
Beam quality	[M ²]	<1,3
Power Supply		24 VDC - 350W
Cooling		Air to Air
Communication (*)	Profibus or Ethernet - Laser Controlling: DB25; Diagnostic: RS232	

AQS6 OEM Layout

RESONATOR

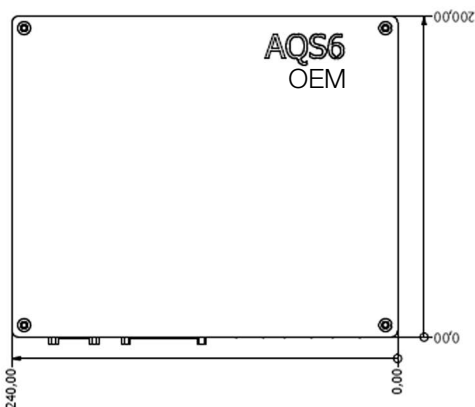
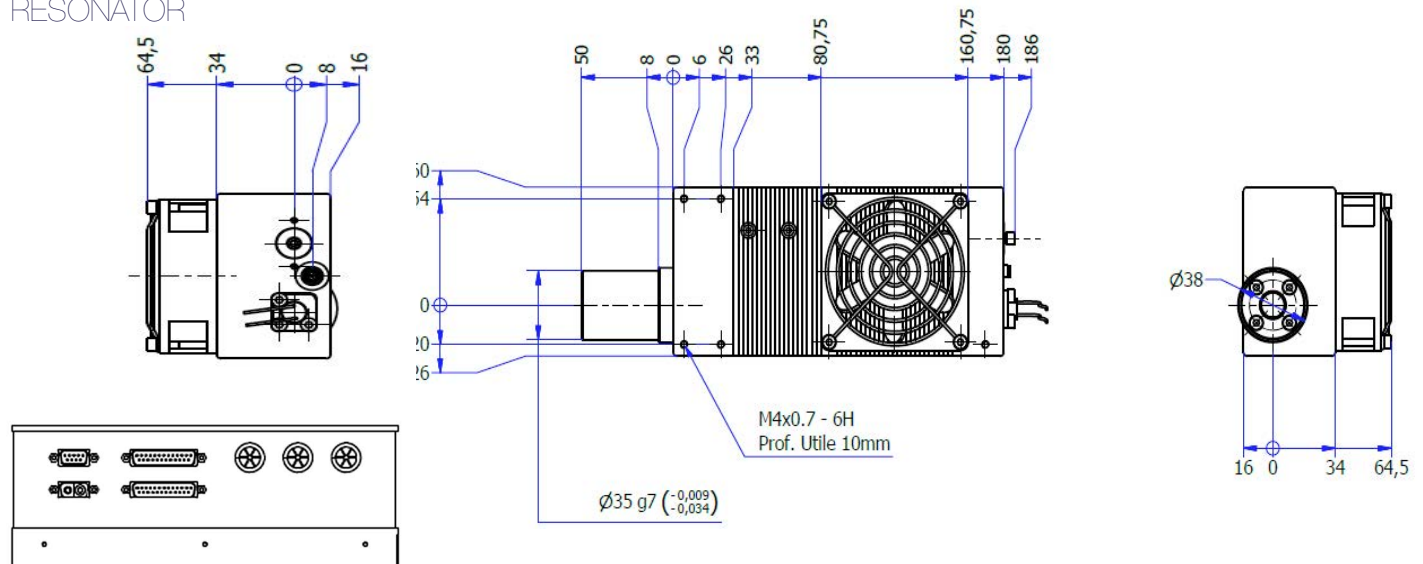

RACK

Specifications are subject to variations and updates without notice.
 Class 4 laser source.
 This OEM laser component is for sale solely to qualified manufacturers, who shall provide interlocks, indicators and other appropriate safety features, in full compliance with 21 CFR 1040 and/or other applicable national and local regulations.



GAP Laser Systems s.r.l.
 A Certified and ISO 9001:2008 Company



Via Oneda, 11 - 21018 Sesto Calende (VA) - ITALY
 Tel: +39 0331 072637 - Fax: +39 0331 072695
 www.gaplaser.com - info@gaplaser.com